

Conceptual Design of High Efficiency Breech-Fed Ablative PPT in Tokyo Metropolitan University

IEPC-2013-263

*Presented at the 33rd International Electric Propulsion Conference,
The George Washington University • Washington, D.C. • USA
October 6 – 10, 2013*

Takahiro Shindo¹, Shinya Mori², Keisuke Tajiri³, Yuya Tamugi⁴, Junichiro Aoyagi⁵ and Haruki Takegahara⁶
*Tokyo Metropolitan University
Hino, Tokyo, 191-0065, Japan*

To achieve higher performance of pulsed plasma thruster (PPT), laboratory model of breech-fed type, which has high energy transfer efficiency, has been designed and built. In addition, in order to understand key factors to increase performance, effects of electrode geometries, electrode's width and gap, on impulse bit, specific impulse, thrust efficiency were investigated. As a result, it was clarified that the electrode geometry strongly affected on not only impulse bit, specific impulse, and thrust efficiency but also discharge waveform which affects impulse bit, capacitor temperature and its lifetime. 27 % of thrust efficiency, which was highest in this study, was achieved with 50 J of input energy.

Nomenclature

A	= propellant ablation area	R_P	= plasma resistance
C	= capacitance	R_{tot}	= total circuit resistance
Δm	= mass shot	t	= electrode thickness
E	= stored energy in capacitor	v_{EM}	= mean current sheet velocity
E_{loss}	= energy loss in capacitor	v_{ET}	= mean neutral particle velocity
g	= gravity acceleration	w	= electrode width
h	= electrode gap	x	= direction of thrust axis
I_{bit}	= impulse bit	Z_{PPT}	= Thruster head impedance
I_{SP}	= specific impulse		
J	= current		
L	= inductance		
L_C	= equivalent series inductance in capacitor		
L_L	= transmission channel inductance		
L_P	= plasma inductance		
m_i	= propellant mass before experiment		
m_f	= propellant mass after experiment		
N	= total shot number of an experiment		
R_C	= equivalent series resistance of capacitor		
R_L	= transmission channel resistance		

¹ Graduate Student, Department of Aerospace Engineering, TMU, t-shindo@astak3.sd.tmu.ac.jp

² Graduate Student, Department of Aerospace Engineering, TMU, s-mori@astak3.sd.tmu.ac.jp

³ Graduate Student, Department of Aerospace Engineering, TMU, k-tajiri@astak3.sd.tmu.ac.jp

⁴ Graduate Student, Department of Aerospace Engineering, TMU, y-tamugi@astak3.sd.tmu.ac.jp

⁵ Assistant Professor, Department of Aerospace Engineering, TMU, j-aoyagi@astak3.sd.tmu.ac.jp

⁶ Professor, Department of Aerospace Engineering, TMU, hal@astak3.sd.tmu.ac.jp

I. Introduction

RECENTLY, micro satellites have been attractive attention from the aspects of low development costs and short development time. As a result, the number of the micro-satellites on orbit has been increased. Generally, micro satellites do not have any propulsion systems; thus, they have difficulty in changing satellite's orbit attributed from atmospheric drag and escaping from orbital debris. As a result, their lifetimes are limited because of no propulsion system. To improve mission duration of micro satellites, small size of propulsion system will be needed, and pulsed plasma thruster (PPT) could be a great propulsion system candidate because they have good reliability and are suitable to control satellite's attitude and orbit maneuver. PPT is one type of electric propulsion system and has simple structure because it uses solid propellant; thus, there are no propellant valves and tanks. In addition, PPT can operate at relatively low power consumption, less than 10 W, in comparison with other types of electric propulsion system. However, thrust efficiency of PPT, which is generally 10 %, is lower than other electric propulsion system.

In our previous study, several types of PPTs have been developed in Tokyo Metropolitan University (TMU). In previous models, 13 % of thrust efficiency was highest at a coaxial type PPT with 50 J of input energy. The relatively low thrust efficiency compared with other electric propulsion system was caused by several factors, for example, late time ablation, low energy transfer efficiency, and not-optimized electrode geometries.

In order to improve thruster performance, effects of energy transfer efficiency and electrode geometry are investigated in this study. The thruster performance means impulse bit, specific impulse, and thrust efficiency in this paper. To improve energy transfer efficiency, new breech-fed type rectangular PPT, which was modified on capacitor bank and transmission channel, has been designed and built, and these thruster performance between previous and current models are compared, discussed in section II and IV.A. Effect of electrode geometries, its width and gap, on thrust efficiency was experimentally evaluated, discussed in section IV.B. Moreover, electrode geometry affects discharge waveform; it is one of factors of capacitor lifetime and maximum operational frequency. These are described in section IV.C.

II. New Breech-fed PPT Laboratory Model

In order to improve thruster performance, stored energy in capacitor should be transferred into thruster head effectively. Generally, PPT system is regarded as series LCR circuit as shown in Fig. 1. In this model, all of stored energy in capacitor is consumed in resistance as joule heating and variable inductance as kinetic energy of current sheet.^{4,5} Energy ratio input into thruster head over stored in capacitor is called energy transfer efficiency η_{trans} . The energy transfer efficiency is defined as below⁶.

$$\eta_{trans} = \frac{Z_{PPT}}{R_{tot}} = \frac{Z_{PPT}}{R_C + R_L + Z_{PPT}} \quad (1)$$

R_{tot} , R_C and R_L are total circuit resistance, equivalent series resistance in capacitor and transmission channel resistance. Z_{PPT} is impedance of thruster head and it is combination of plasma resistance and back electro motive force (EMF). Z_{PPT} is described as below.

$$Z_{PPT} = R_p + \frac{1}{2} \frac{dL}{dt} \quad (2)$$

As shown in Eq. 1, η_{trans} is described with resistance and thruster head impedance. Hence, in order to improve η_{trans} , resistance in external circuit needs to be smaller than Z_{PPT} .

Previous and new models, which had been developed in our laboratory, are described from the point of view of energy transfer efficiency, in following subsections.

A) Previous Model

Previous PPTs, which were developed in our laboratory, have either single core or coaxial cables for transmission channel. Because the flexibility of cable allows to connect between the capacitor bank and thruster head easily; and to design PPT which contained a driving part in discharge electrode.⁷⁻⁹ However, these cables had

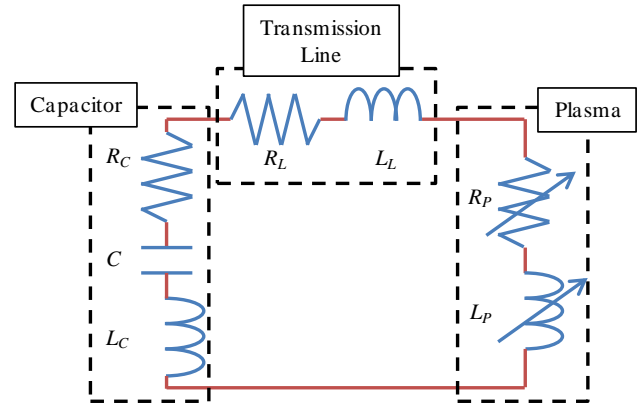

Figure 1. Equivalent series LCR circuit.

about 20 mΩ of ohmic resistance; thus, it is not negligible value in comparison with total system resistance, which was about 60 mΩ. The capacitor bank in this model consisted of 250 capacitors; thus a lot of lead terminals have been used for connecting them. It could be assumed that equivalent series resistance of capacitor bank was high. Therefore, these resistance decline energy transfer efficiency, and it caused low thruster performance.

B) New Laboratory Model

New laboratory model was designed and built for the purpose of increasing energy transfer efficiency by reducing resistance in transmission channel and capacitor bank, as shown in Fig. 2. It consists of capacitor bank, transmission channel, electrodes, propellant and igniter. The capacitor bank consists of four 10 mF oil impregnated film capacitors. In this study, input energy was set to 50 J, and the bank was charged up at 1,620 V and 0.75 Hz of operational frequency by main power supply. The operational frequency was limited by current limitation of the main power supply.

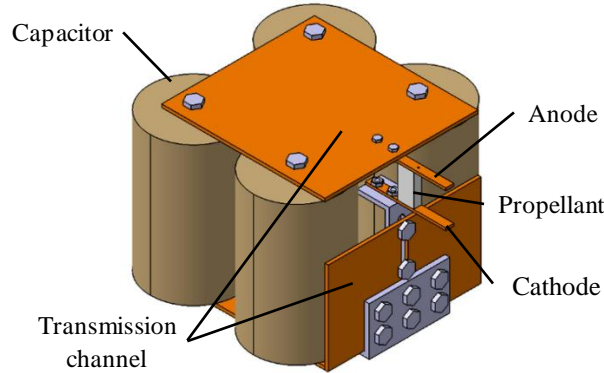

Figure 2. Schematic of new PPT.

In transmission channel, reduction of resistance and inductance were achieved by using large copper plate for transmission channel. By using copper plate, transmission channel resistance was reduced from 20 mΩ to less than 1mΩ. Due to refine the capacitor bank and the transmission channel, 30 mΩ of total circuit resistance was achieved.

Thruster head electrodes, anode and cathode, are made of copper. Figure 3 shows schematic of thruster head. Thickness of electrode was kept 3 mm throughout this study. Basic size of electrode's width w and gap h are 20 mm and 40 mm, respectively. In order to investigate effect of electrode's width and gap on thruster performance, several discharge electrode geometries were employed, summarized in Table 1. It must be noted that 20 mm of width and gap was not employed in this study because peak discharge current exceeds maximum current limitation of the capacitor bank attributed from lower impedance.

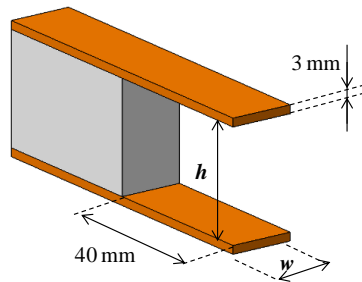

Figure 3. Schematic of thruster head.

Table 1. Experimental conditions of electrode geometry.

Electrode width, w	Electrode gap, h
10	20, 30, 40, 50
15	20, 30, 40, 50
20	30, 40, 50

Solid propellant is made of polytetrafluoroethylene (PTFE). Its width was 1mm wider than electrode width w to prevent creeping discharge on side surface of propellant. Propellant ablation area A is defined as follows.

$$A = h \times (w + 0.1) \text{ , cm}^2 \quad (3)$$

Igniter consists of semiconductor plug, it is attached on cathode. Spark discharge which initiates discharge between anode and cathode is caused by applying pulse voltage to the plug from a pulse power supply. The spark discharge energy is fixed at 49 mJ.

III. Experimental Apparatus and Evaluation Criteria

Figure 4 shows a schematic of experimental configuration. All experiments had been conducted in a vacuum chamber, and its diameter and length were 1.0 m and 1.8 m respectively. Backpressure in the vacuum chamber was kept at 4×10^{-3} Pa. Target pendulum was used for thrust measurement system. Swing of the pendulum was measured by using laser displacement meter, and impulse bit was calculated from the displacement. Discharge current and voltage were measured by rogowski coil and high voltage probe.

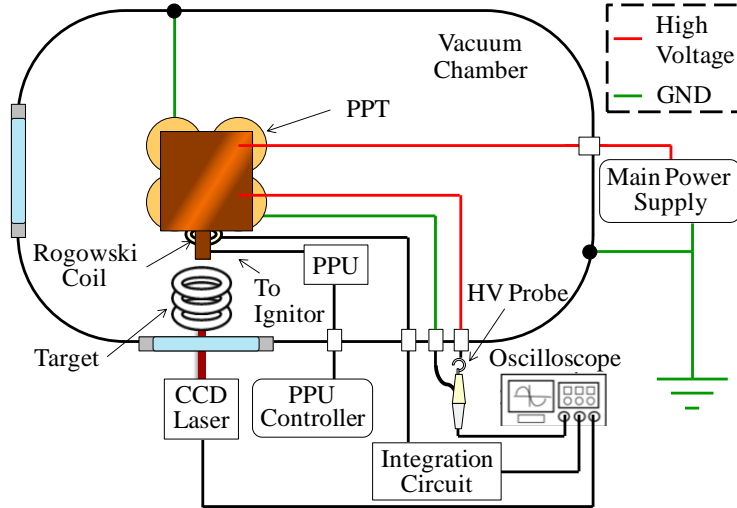

Figure 4. Experimental configuration.

In order to evaluate thruster performance, mass shot Δm , specific impulse I_{SP} and thrust efficiency η were defined as below.

$$\Delta m = \frac{m_i - m_f}{N} \quad (4)$$

$$I_{SP} = \frac{I_{bit}}{g \cdot \Delta m} \quad (5)$$

$$\eta = \frac{I_{bit}^2}{2\Delta m \cdot E} \quad (6)$$

Where m_i and m_f is propellant mass before and after experiment respectively, E is input energy, and N is discharge number which was fixed at 5,000 shot in each experiment. I_{bit} in Eq. (5) and (6) is measured value.

IV. Result and Discussion

A) Comparison of thruster performance of previous and new PPT

Table 2 shows the thruster performances between previous and new PPT at same energy and electrode geometry.⁹ Structural differences of these PPTs are transmission channel and capacitor bank. It means that these PPTs have different energy transfer efficiency. Thus, the performance improvement, as shown in Table 2, was caused by improving of the energy transfer efficiency.

Table 2. Thruster performances comparison with previous and new PPT.

	Previous TMU PPT	New TMU PPT
Input energy, J	50	50
Electrode geometry ($w \times h$), mm	20×40	20×40
Impulse Bit, mNs	0.40	1.02
Specific Impulse, s	1,100	1,930
Thruster Efficiency, %	4.3	19.4

B) Effect of Electrode Geometry on Thruster Performance

Figure 5 shows measured impulse bit as functions of electrode gap and width. From this result, electrode gap affect impulse bit significantly. However, the width did not affect impulse bit. This result will be discussed by using theoretical equation and obtained value as following. Theoretical impulse bit of PPT is written as below.

$$I_{bit} = \frac{1}{2} \frac{dL}{dx} \int J^2 dt + \Delta m v_{ET} \quad (7)$$

On right hand side, first term is electromagnetic force, and second term is electrothermal force. At first, electromagnetic force in impulse bit is discussed below. If discharge electrode of the PPT is parallel rectangular shape as shown in Fig. 3, the inductance gradient is approximated as below.

$$\frac{dL}{dx} = 0.6 + 0.4 \ln \left(\frac{h}{t+w} \right) \quad \mu\text{H/m} \quad (8)$$

Generally, the electromagnetic force is dominant with breech fed type PPT. Thus, from Eq. (7) and (8), it is assumed that impulse bit is increased with increasing electrode gap and narrowing width. However, measured impulse bit did not be affected by the width. This trend was caused by changes in discharge current and mass shot. $\int J^2 dt$ is written as below

$$\int J^2 dt = \frac{E}{R_{tot}} \cong \frac{E}{R_C + R_L + Z_{PPT}} \quad (9)$$

where, Z_{PPT} is written with inductance gradient and mean current sheet velocity v_{EM}

$$\frac{1}{2} \frac{dL}{dt} = \frac{1}{2} \frac{dL}{dx} v_{EM} \approx \frac{1}{2} \left(0.6 + 0.4 \ln \frac{h}{w+t} \right) v_{EM} \quad (10)$$

Equations (9) and (10) indicate that reducing inductance gradient by widening the width leads to reduction of thruster head impedance, and it raise $\int J^2 dt$. Figure 6 shows measured $\int J^2 dt$ as functions of electrode geometries. These results were accorded with Eq. (9) and (10). Therefore, the increment of $\int J^2 dt$ by widening the electrode width prevented to reduction of electromagnetic force.

On the other hand, in electrothermal force, it depends on mass shot and neutral particle velocity. In this study, the velocity could not be measured. Measured mass shot of each electrode geometries are shown in Fig. 7. Mass shot was increased linearly with propellant area. Therefore it can be assumed that mass shot depend on strongly not energy density and aspect ratio but propellant area with these geometries. However the liner approximated value of mass shot is not 0 at propellant ablation area is 0. Thus the linear relation probably will not formed when use smaller propellant. From this result, wider electrode width and larger electrode gap generate more mass shot, thus it increase electrothermal force. Because of these result, electrode width did not affect impulse bit significantly.

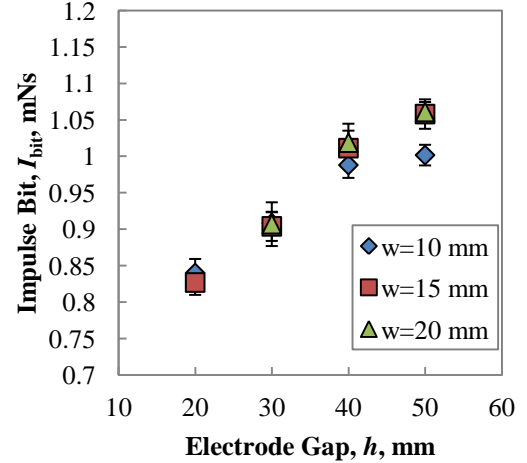

Figure 5. Measured Impulse bit as functions of electrode geometries.

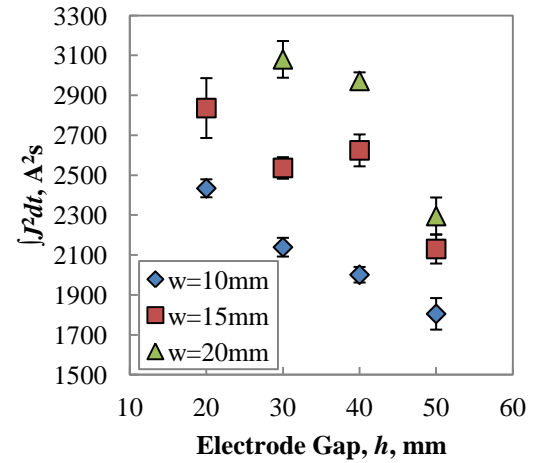

Figure 6. Measured $\int J^2 dt$ as functions of electrode geometries.

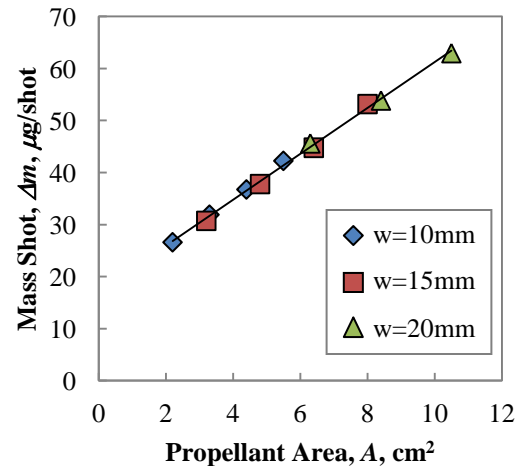

Figure 7. Measured mass shot as a function of propellant area.

Inductance gradient could be approximated as ideal parallel rectangular plate's one which is proportional to aspect ratio h/w .¹⁰ Therefore impulse bit (or thrust) is evaluated as a function of aspect ratio. From this result, however, different impulse bit were obtained with same aspect ratio (in this study, $w=10, h=20$ and $w=20, h=40$ mm) thus, aspect ratio is not effective parameter to determine the geometry.

Figure 8 shows effect of electrode geometry on specific impulse. In order to evaluate correlation between electrode geometry and specific impulse, energy density E/A is used. In breech-fed type, the correlation is reported as following.¹¹

$$I_{SP} = 247 \times \left(\frac{E}{A} \right)^{0.87} \quad (11)$$

On the other hand, the result of this experiment is

$$I_{SP} = 1100 \times \left(\frac{E}{A} \right)^{0.35} \quad (12)$$

Results of this study are higher in low energy density region and lower in high energy density region in comparison with the results in Ref. 8. This difference may be caused by difference of energy transfer efficiency. For example, even same E/A , different specific impulses were obtained summarized in table 2.

Thrust efficiency strongly depended on electrode width as shown in Fig. 9. Because widening electrode width did not decrease impulse bit, however it increased mass shot linearly. On the other hand, in the impedance point of view, narrow width electrode has high thruster head impedance. This higher impedance probably increases energy transfer efficiency; thus, thrust efficiency depends on the width strongly.

C) Effect of electrode geometry on capacitor

From the results discussed above, electrode width did not affect impulse bit significantly. Therefore if PPT system is allowed to equip enough amount of propellant bar, lower specific impulse, caused by wide width electrode, will be covered. In this case, electrode width has little importance to thruster performance. However, in the point of view of capacitor, the width has great importance for its temperature and lifetime.

Energy loss in capacitor per discharge E_{loss} is

$$E_{loss} = R_C \cdot \int J^2 dt \quad (12)$$

This energy is consumed as joule heating it raises capacitor temperature. Capacitor is weak against heat, generally up to 85 °C or 105 °C, therefore one of factor limits maximum operational frequency is capacitor temperature.¹² To reduce joule heating in capacitor without decline thruster performance, narrow electrode width should be chosen. As shown in Fig. 6, Eq. (9) and (10), higher aspect ratio electrode has higher impedance. Hence it reduces $\int J^2 dt$ with little (or without) performance degradation. For example at $h=40$ mm, $w=10$ and 20 mm electrode generate nearly same impulse bit, however the $\int J^2 dt$ of $w=10$ mm is 67 % of $w=20$ mm.

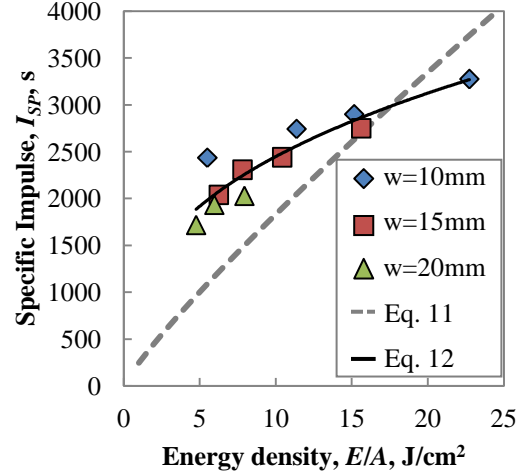

Figure 8. Specific impulse as a function of energy density.

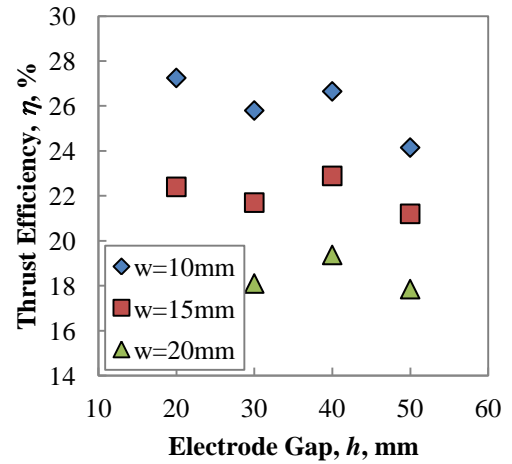

Figure 9. Thrust efficiency as functions of electrode geometries.

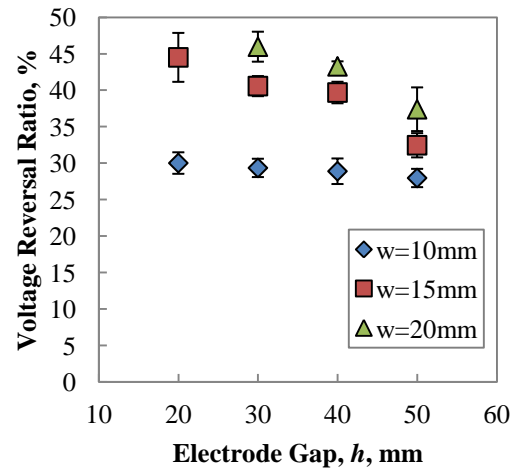

Figure 10. Voltage reversal ratio as functions of electrode geometry.

Moreover, the impedance affects voltage reversal of capacitor during discharge as shown in Fig. 10. In thruster head, the reversal causes current sheet restrike, it decreases thruster performance.¹ On the other hand in capacitor, the reversal electric field damage to capacitor dielectric, thus, it increases R_C and shorten capacitor life.⁴ To withstand higher voltage reversal, thicker dielectric should be needed. However, it increases capacitor size and cost.

Thus high voltage reversal ratio decreases performance and increases capacitor size and cost by increasing its working voltage. Adjusting electrode geometry also partially solves these problems.

Considering from these result, combination of $w=10$ mm and $h=40$ mm is best geometry in this study. By using this electrode, 1 mNs of impulse bit, 2,700 s of specific impulse and 27 % of thrust efficiency were achieved with 50 J of input energy.

V. Conclusion

In order to obtain high thruster performance, new PPT, which is modified energy transfer efficiency, was built. This PPT achieved high performance compared with previous PPT with same electrode geometry; the effect of improvement transfer efficiency was confirmed.

Effects of electrode geometry were investigated by changing its width 10-20 and gap 20-50 mm with input energy 50 J. Impulse bit increased with increasing electrode gap, on the other hand, electrode width did not affect significantly because of changes of mass shot and thruster head impedance. The mass shot was increased linearly with propellant ablation surface area. The impedance was reduced by widening the width and narrowing the gap. Because of this effect, impulse bit did not be reduced with wider width electrode in this study. Specific impulse was increased with decreasing propellant ablation surface area; it is same tendency of other studies. Specific impulses obtained in this study were higher in low energy density region and lower in high energy density region compared with reported value. Thrust efficiency strongly depended on electrode width. It is because electrode width did not affect to impulse bit, on the other hand, it affect mass shot significantly. Moreover, from the point of view of energy balance, electrode width affect energy transfer efficiency due to impedance changes, thus the width affected thrust efficiency significantly.

Impedance variation by changing electrode geometry also affects on discharge waveform. High impedance which is generated high aspect ratio electrode reduces joule heating in capacitor and reversal percentage of voltage. It removes thermal and electrical stress in capacitor partially.

As a best performance in this study, 1 mNs of impulse bit, 2,700 s of specific impulse and 27 % of thrust efficiency were achieved with 10 mm of width and 40 mm of gap electrode geometry.

VI. Reference

- ¹Burton R. L. and Turchi P. J. "Pulsed Plasma Thruster" *Journal of Propulsion and Power*, Vol. 14, No. 5, 1998
- ²Molina-Cabrera P., Herdrich G. Lau M. Fausolas S. Schoenherr T. and Komurasaki K. "Pulsed Plasma Thrusters: a worldwide review and long yearned classification" 32nd International Electric Propulsion Conference, IEPC-2011-340
- ³Kitazono Y., Umeda K., Mimura D., Aoyagi J., Takegahara H. "Influence of Input Energy Increase on Thrust Performance of Coaxial Pulsed Plasma Thruster" 61st International Astronautical Congress, IAC-10.C4.4.9
- ⁴"The Effect of Reversal on Capacitor Life" General Atomics Energy Products Engineering Bulletin 96-004, November 2003
- ⁵Edamitsu T., Asakura H., Matsumoto A. and Tahara H. "Research and Development of a Pulsed Plasma Thruster in Osaka University" 29th International Electric Propulsion Conference, IEPC-2005-106
- ⁶Burton R. L., Wilson M. J., and Bushman S. S. "Energy Balance and Efficiency of the Pulsed Plasma Thruster" 34th Joint Propulsion Conference, 1998, AIAA-98-3808
- ⁷Kumagai, N., Sato, K., Tamura, K., Kawahara, K., Koide, T., Takegahara H., Sugiki, M., Wakizono, T., and Hashimoto, H., "Research and Development Status of Low Power pulsed Plasma Thruster System for μ -Lab Sat II" 28th International Electric Propulsion Conference, IEPC-03-0202
- ⁸Umeda K., Shintani K., Kubota Y., Kitazono Y., Aoyagi J., and Takegahara H. "Research and Development on Coaxial Pulsed Plasma Thruster with Feed Mechanism" 31th International Electric Propulsion Conference, IEPC-2009-255
- ⁹Mimura D., Umeda K., Kitazono Y., Shindo T., Aoyagi J., and Takegahara H. "Evaluation of Pulsed Plasma Thruster Performance by Increase of Electric Power" 32nd International Electric Propulsion Conference, IEPC-2011-306
- ¹⁰Robert G. Jahn "Physics of Electric Propulsion" McGRAW-HILL Book Company
- ¹¹Gessini P., Paccani G. "Ablative Pulsed Plasma Thruster System Optimization for Microsatellites" 27th International Electric Propulsion Conference, IEPC-01-182
- ¹²Antropov N. N., Kazeev M. N., Khodnenko V. P. "High Thrust APPTs for Spacecraft Orbit Control" 31st International Electric Propulsion Conference, IEPC-2009-248